

Please check the examination details below before entering your candidate information

Candidate surname

Other names

Pearson Edexcel
Level 1/Level 2 GCSE (9–1)

Centre Number

--	--	--	--	--

Candidate Number

--	--	--	--

Time 1 hour 10 minutes

**Paper
reference**

1SC0/1CF

Combined Science
PAPER 2
Foundation Tier

You must have:
Calculator, ruler

Total Marks

Instructions

- Use **black** ink or ball-point pen.
- **Fill in the boxes** at the top of this page with your name, centre number and candidate number.
- Answer **all** questions.
- Answer the questions in the spaces provided – *there may be more space than you need.*
- Calculators may be used.
- Any diagrams may NOT be accurately drawn, unless otherwise indicated.
- You must **show all your working out** with **your answer clearly identified** at the **end of your solution**.

Information

- The total mark for this paper is 60.
- The marks for **each** question are shown in brackets – *use this as a guide as to how much time to spend on each question.*
- In the question marked with an **asterisk (*)**, marks will be awarded for your ability to structure your answer logically showing how the points that you make are related or follow on from each other where appropriate.
- There is a periodic table on the back cover of the paper.

Advice

- Read each question carefully before you start to answer it.
- Try to answer every question.
- Check your answers if you have time at the end.
- Good luck with your examination.

Turn over ►

P66622A

©2021 Pearson Education Ltd.

1/1/1



Pearson

Answer ALL questions. Write your answers in the spaces provided.

Some questions must be answered with a cross .
If you change your mind about an answer, put a line through the box and then mark your new answer with a cross .

1 If liquid water is cooled below 0°C it turns into the solid, ice.

(a) (i) Give the name for the change of state from liquid to solid.

(1)

(ii) Here are five statements about ice and water.

Place ticks in boxes by the **two** statements that are correct.

(2)

the molecules move faster in water than in ice	<input type="checkbox"/>
the molecules are more randomly arranged in ice than in water	<input type="checkbox"/>
the molecules start moving when water becomes ice	<input type="checkbox"/>
the molecules are arranged regularly in ice but not in water	<input type="checkbox"/>
the molecules have more energy in ice than in water	<input type="checkbox"/>

DO NOT WRITE IN THIS AREA

DO NOT WRITE IN THIS AREA

DO NOT WRITE IN THIS AREA



(b) Figure 1 shows a label from a bottle of drinking water.

Pure drinking water	
Mass of dissolved solids in mg per 1000 cm ³	
calcium ions	60
sodium ions	2
hydrogencarbonate ions	200
pH of water	
pH	7

Figure 1

(i) Explain why this drinking water should not be described as pure water. (2)

.....

.....

(ii) State the information from Figure 1 that shows that the drinking water is neutral. (1)

.....

(iii) Calculate the mass of calcium ions in 250 cm³ of this drinking water. (2)

.....

.....

mass = mg

(c) State how you know that calcium is a metal from its position in the periodic table. (1)

.....

.....

(Total for Question 1 = 9 marks)



2 (a) When chromium reacts with oxygen, chromium oxide is formed.

(i) Write the word equation for this reaction.

(1)

..... + →

(ii) What type of reaction occurs when chromium reacts with oxygen?

(1)

- A** condensation
 B evaporation
 C neutralisation
 D oxidation

(iii) Calculate the relative formula mass of chromium oxide, Cr_2O_3 .

(relative atomic masses: O = 16, Cr = 52)

(2)

.....
.....
relative formula mass =

(b) Three different metals are added to separate test tubes of acid.

The observations are shown in Figure 2.

metal	observation
silver	no change is seen
iron	very slow bubbling
magnesium	steady bubbling

Figure 2

(i) Place the metals in order of reactivity from most to least reactive.

(1)

most reactive

.....

least reactive



(ii) Hydrogen is given off when magnesium reacts with acid.
The hydrogen is tested by collecting the gas in a test tube and igniting it.

What is the safest way to ignite the gas? (1)

- A add fuel to the test tube
- B heat the test tube with a Bunsen burner
- C put a lighted splint at the open end of the test tube
- D put the test tube in an oven

(iii) State the observation made in this test that shows that the gas is hydrogen. (1)

.....

.....

(c) Iron is extracted by heating iron oxide with carbon.
Electrolysis of molten iron oxide is not used to extract iron.

(i) State why iron can be extracted by heating iron oxide with carbon. (1)

.....

.....

(ii) State why electrolysis is **not** used to extract iron. (1)

.....

.....

.....

.....

(Total for Question 2 = 9 marks)

DO NOT WRITE IN THIS AREA

DO NOT WRITE IN THIS AREA

DO NOT WRITE IN THIS AREA



3 Ammonia is made by reacting nitrogen with hydrogen.

(a) The nitrogen and hydrogen are obtained from raw materials.

Draw one straight line from each gas to the raw material it is obtained from.

(2)

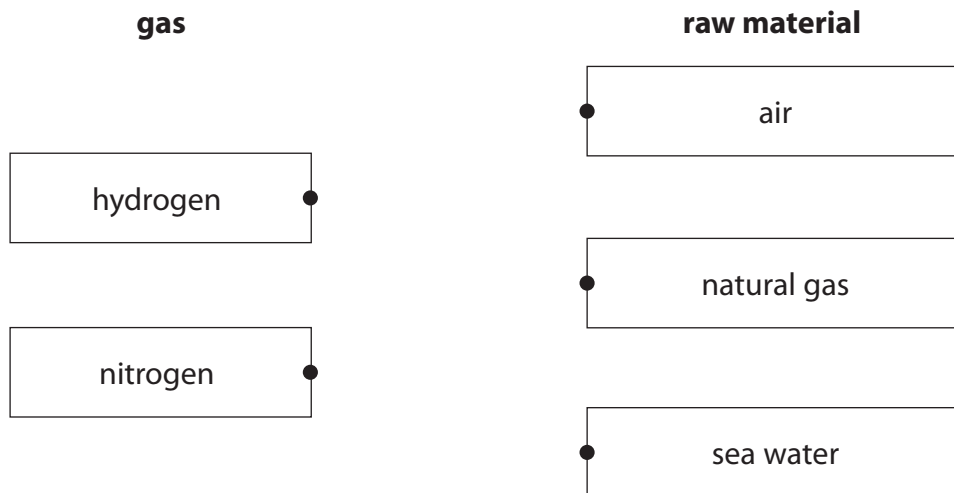

(b) When nitrogen and hydrogen are reacted together, the reaction can reach a dynamic equilibrium.

Use words from the box to complete the sentences about dynamic equilibrium.

(2)

backward
different
equal
faster
reversible

In a dynamic equilibrium two reactions occur at the same time.

These are the forward reaction and the reaction.

The rates of the two reactions are

(c) The reaction between nitrogen and hydrogen happens at a pressure of 200 atmospheres.

Another unit of pressure is Pascals, Pa (1 atmosphere = 101 325 Pa).

Calculate the value of 200 atmospheres in Pascals.

(2)

.....

.....

pressure = Pa



(d) Figure 3 shows molecules of nitrogen, hydrogen and ammonia before the reaction and at equilibrium.

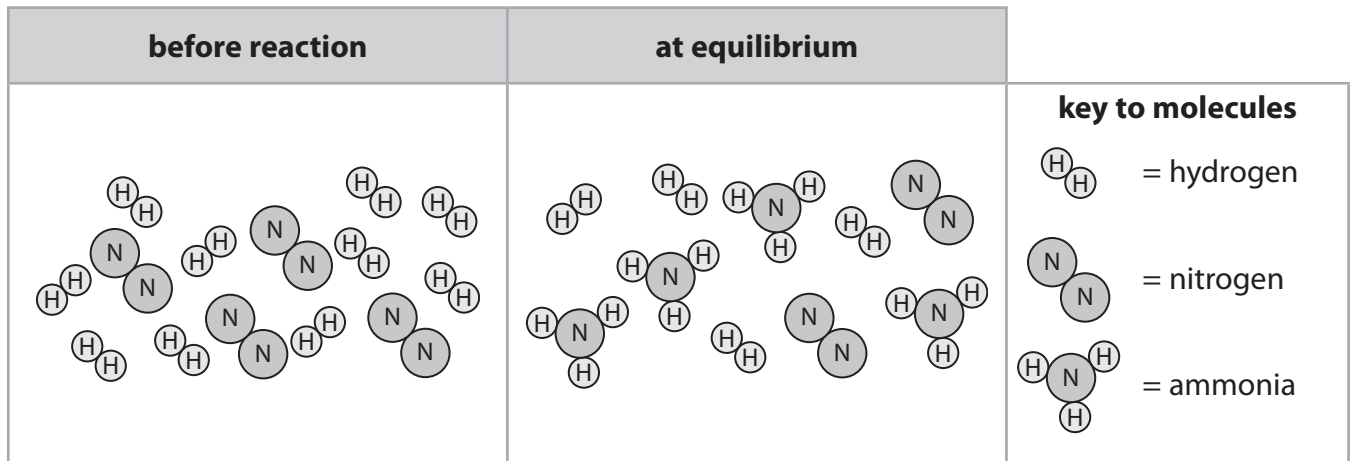

Figure 3

(i) Complete the table showing

- the number of hydrogen molecules before reaction
- the number of hydrogen molecules at equilibrium
- the change in the number of hydrogen molecules.

(1)

	number of molecules before reaction	number of molecules at equilibrium	change in number of molecules
nitrogen	4	2	-2
hydrogen
ammonia	0	4	+4

(ii) Complete the equation for this reaction.

(2)



(Total for Question 3 = 9 marks)



DO NOT WRITE IN THIS AREA

DO NOT WRITE IN THIS AREA

DO NOT WRITE IN THIS AREA

- 4 (a) Hydrochloric acid reacts with solid **B**.
Solid **B** is an alkali.

A student carries out an experiment to see how the pH changes when different masses of solid **B** are added to dilute hydrochloric acid.

The student uses the following method.

step 1 use a measuring cylinder to measure out 100cm^3 of dilute hydrochloric acid

step 2 pour the acid into a beaker

step 3 measure the pH with a pH probe

step 4 add half a spatula of solid **B** and stir

step 5 repeat steps 3 and 4 until the pH stops changing.

- (i) Give a safety precaution that should be taken during the experiment. (1)

- (ii) Give an improvement to step 4 that would produce more accurate results. (1)

- (iii) What is the most likely change in pH during the experiment? (1)

- A** from 1 to 7
 B from 1 to 12
 C from 7 to 12
 D from 12 to 1

- (iv) If some methyl orange indicator is added to the acid in step 2, the mixture changes colour during the experiment.

State the colour change. (2)

colour at start in acid colour at end



(b) Concentrated hydrochloric acid can be broken down using electricity.
The apparatus that can be used is shown in Figure 4.

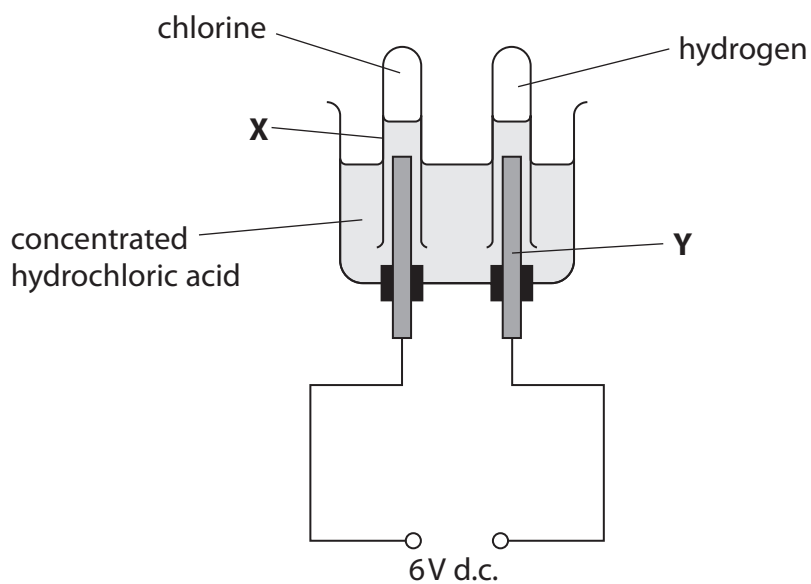

Figure 4

(i) Give the name of the piece of apparatus labelled X.

(1)

(ii) The rod labelled Y in Figure 4 is made of graphite.

What is the name of this piece of apparatus?

(1)

- A electrode
- B electrolysis
- C electrolyte
- D electron

(iii) Give **one** reason why graphite is a suitable material to make Y.

(1)

(iv) Complete the balanced equation for the reaction that occurs.

(1)

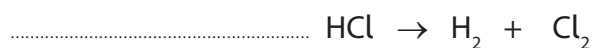

(Total for Question 4 = 9 marks)



5 The scientist John Dalton lived over 200 years ago.

(a) John Dalton suggested an early model of atoms.

When Dalton first described atoms he said that

- all elements are made of atoms
- atoms are not formed of any smaller particles
- all atoms of the same element are identical.

Give two differences between Dalton's model of atoms and today's model of atoms.

(2)

1

.....

.....

2

.....

.....

(b) Dalton also investigated different gases.

One of the gases that Dalton investigated was ethene.

The structure of one molecule of ethene is shown in Figure 5.

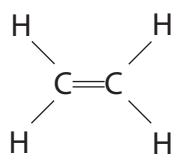

Figure 5

Give the molecular formula and the empirical formula of ethene.

(2)

molecular formula

empirical formula



(c) Another gas that Dalton investigated was chlorine.

Chlorine gas reacts with water.

The two products are a solution of hydrogen chloride and the substance HClO.

(i) Complete the balanced equation for this reaction, including the three missing state symbols.

(3)

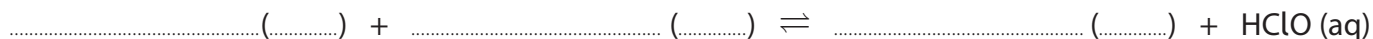

(ii) Hydrogen chloride solution is acidic.

The formulae of four ions are shown in Figure 6.



Figure 6

Give the formula of the ion in Figure 6 that causes the hydrogen chloride solution to be acidic.

(1)

formula

(iii) An acid reacts with an alkali.

Give the name of this type of reaction.

(1)

(iv) Describe what you would **see** when some copper carbonate powder is added to a beaker of dilute sulfuric acid.

(2)

(Total for Question 5 = 11 marks)



6 (a) A sample of potable water contains impurities.

Why is this sample of water potable even though it contains impurities?

(1)

- A** the impurities have no smell
- B** the impurities are colourless
- C** the impurities are harmless
- D** the impurities are soluble

(b) Waste water can be used to produce drinking water.

The processes used include sedimentation, filtration and chlorination.

(i) What is sedimentation?

(1)

- A** the waste water is heated so the impurities evaporate
- B** the waste water has an acid added to remove impurities
- C** the impurities in the waste water settle to the bottom of their container
- D** the impurities in the waste water are bleached

(ii) State why the waste water is filtered.

(1)

.....

.....

(iii) State the reason for chlorination.

(1)

.....

.....

.....



- (c) Some salts can be added to waste water to remove impurities. In an experiment, different masses of salt **A** were added to 1000 cm^3 samples of waste water. The experiment was repeated with salt **B**. The percentages of impurities removed from the waste water are shown in Figure 7.

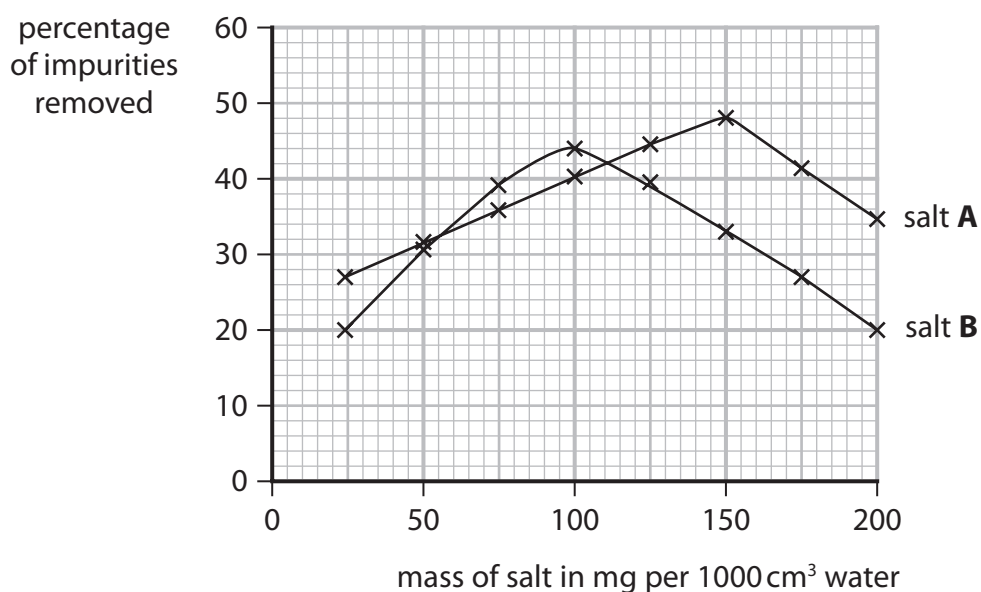

Figure 7

It was concluded that the best way to purify 1000 cm^3 of the waste water is to add 100 mg of salt **B**.

Use the information about salt **A** and salt **B** in Figure 7 to evaluate this conclusion.

(3)

.....

.....

.....

.....



*(d) A sample of water was contaminated with a dissolved solid.

Devise a plan to separate pure water from this mixture, including a test to show that the water obtained is neutral.

You may use some or all of the apparatus shown in Figure 8 and any other laboratory apparatus.

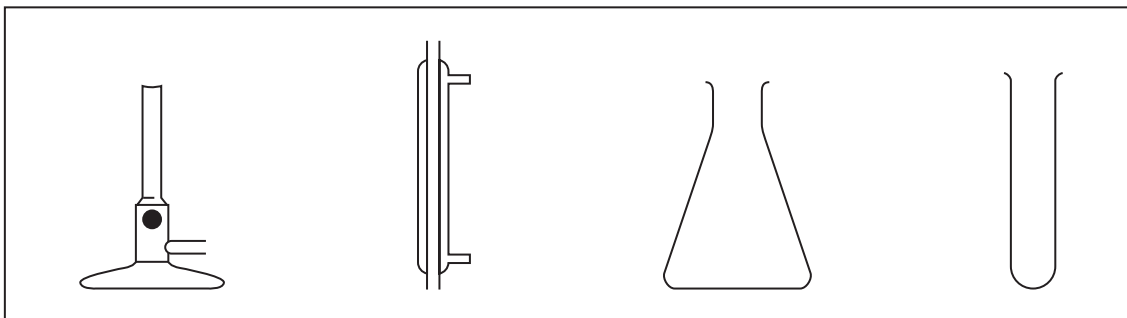

Figure 8

(6)

Area with horizontal dotted lines for writing the answer.

DO NOT WRITE IN THIS AREA

DO NOT WRITE IN THIS AREA

DO NOT WRITE IN THIS AREA



DO NOT WRITE IN THIS AREA

DO NOT WRITE IN THIS AREA

DO NOT WRITE IN THIS AREA

(Total for Question 6 = 13 marks)

TOTAL FOR PAPER = 60 MARKS



P 6 6 6 2 2 A 0 1 5 1 6

The periodic table of the elements

1	2	3	4	5	6	7	0		
7 Li lithium 3	9 Be beryllium 4	11 Na sodium 11	12 C carbon 6	13 Al aluminium 13	14 N nitrogen 7	15 P phosphorus 15	16 O oxygen 8	17 F fluorine 9	18 Ne neon 10
19 K potassium 19	20 Ca calcium 20	23 Na sodium 11	24 Mg magnesium 12	27 Co cobalt 27	28 Si silicon 14	29 Zn zinc 30	31 Ga gallium 31	32 Ge germanium 32	35.5 Cl chlorine 17
37 Rb rubidium 37	38 Sr strontium 38	39 K potassium 19	40 Ca calcium 20	45 Sc scandium 21	48 Ti titanium 22	51 V vanadium 23	52 Cr chromium 24	55 Mn manganese 25	56 Fe iron 26
85 Rb rubidium 37	88 Sr strontium 38	89 Y yttrium 39	90 Zr zirconium 40	91 Y yttrium 39	93 Nb niobium 41	96 Mo molybdenum 42	101 Ru ruthenium 44	103 Rh rhodium 45	106 Pd palladium 46
133 Cs caesium 55	137 Ba barium 56	139 La* lanthanum 57	178 Hf hafnium 72	186 Re rhenium 75	190 Os osmium 76	192 Ir iridium 77	195 Pt platinum 78	197 Au gold 79	201 Hg mercury 80
131 Xe xenon 54	127 I iodine 53	128 Te tellurium 52	122 Sb antimony 51	119 Sn tin 50	115 In indium 49	112 Cd cadmium 48	108 Ag silver 47	106 Pd palladium 46	103 Rh rhodium 45
[222] Rn radon 86	[210] At astatine 85	[209] Po polonium 84	209 Bi bismuth 83	207 Pb lead 82	204 Tl thallium 81	197 Au gold 79	195 Pt platinum 78	192 Ir iridium 77	190 Os osmium 76

1	H hydrogen 1
---	---------------------------

Key
relative atomic mass
atomic symbol
name
atomic (proton) number

* The elements with atomic numbers from 58 to 71 are omitted from this part of the periodic table.

The relative atomic masses of copper and chlorine have not been rounded to the nearest whole number.



DO NOT WRITE IN THIS AREA

DO NOT WRITE IN THIS AREA

DO NOT WRITE IN THIS AREA